

◆ Horizontal Solution Heat Treat Furnace

Designed for smaller components



The horizontal solution heat treat furnace is used for heat treating smaller components and provides many of the features of more expensive drop bottom type furnaces.

Installation effort required for this furnace is minimal. The furnace utilizes a powered roller conveyor system and a pneumatically operated quench elevator located directly in front of the furnace above the quench tank. The elevator is complete with guide columns and is shipped preassembled ready for immediate set-up. Air piping and interconnecting wiring from the furnace to the control cabinet must be accomplished in the field. The door is pneumatically clamped against the furnace front for a tight seal.

FEATURES AT A GLANCE

- ◆ Delivered ready for production
- ◆ Simple, touch-screen operator control
- ◆ Economical for small part or low production runs
- ◆ Easy to install
- ◆ Excellent uniformity ($\pm 5^{\circ}\text{F}$)
- ◆ Automatic operation
- ◆ Quench tank agitation standard
- ◆ Quench tank heater

OPTIONS

- ◆ Alternate instrumentation
- ◆ Basket design and construction
- ◆ Installation and startup



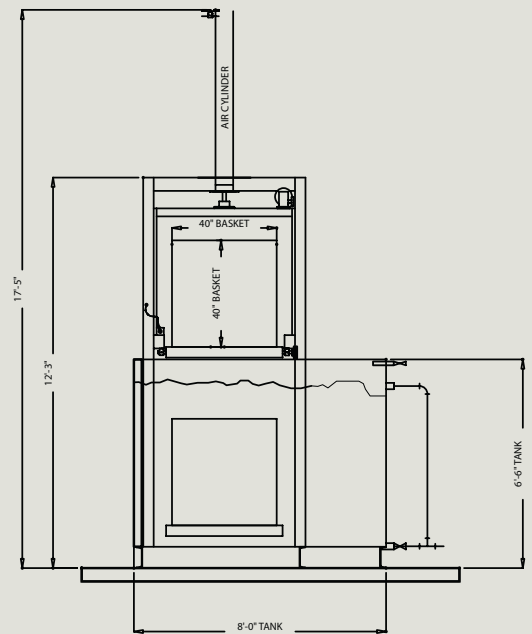
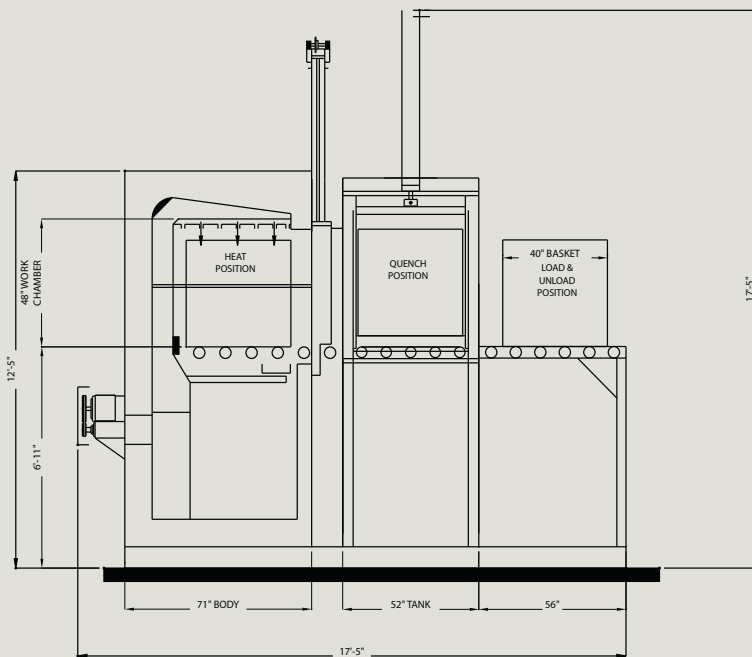

SPECIFICATIONS

- ◆ Quench time: 7 - 10 seconds
- ◆ Capacity, load weight:
Maximum of 650lbs (including basket)
- ◆ Quench tank agitation:
Propeller type mixer
- ◆ Maximum operating temperature:
593°C/1100°F
- ◆ Electricity: 480/3/60
- ◆ Air: 100 PSIG
- ◆ Water: City
- ◆ Exhaust: None

OPERATION

The furnace is preheated. The operator loads the work basket onto the load and unload conveyor. When the operator pushes the cycle start button, the furnace door opens automatically and the work basket is conveyed across the quench elevator roller bed and into the furnace. The pre-programmed heat cycle is run using the touch screen operator control and is timed by the PLC for the required heat cycle. After the heat cycle is completed, the furnace door automatically opens and the work basket is conveyed onto the quench elevator. The furnace door automatically closes after the work basket has exited the furnace and the work basket is then quenched automatically. The work basket is automatically raised from the quench tank, allowed to drip dry, then is conveyed to the load and unload conveyor station for removal by the operator.

SERVICE AND TECHNICAL SUPPORT

service parts: 1-800-473-7373
international service/main: 1-952-469-8230
service fax: 1-952-469-8193
 service@despatch.com

GLOBAL HEADQUARTERS

phone: 1-888-DESPATCH (1-888-337-7282)
international/main: 1-952-469-5424
fax: 1-952-469-4513
 info@despatch.com
 www.despatch.com

8860 207th Street West
 Minneapolis, MN 55044 USA